

PARTS LIST			
ITEM	QTY	PART NO.	PART DESCRIPTION
1	1	SCX3	3/8" x 8" x 9-1/4" CROSSOVER PLATE
2	4	GUB-4355	1/2" x 3-5/8" x 5" GALV U-BOLT KIT

U-BOLT KIT INCLUDES:
 (1) GALVANIZED U-BOLT
 (2) GALVANIZED LOCK WASHERS
 (2) GALVANIZED FLAT WASHERS
 (2) GALVANIZED NUTS

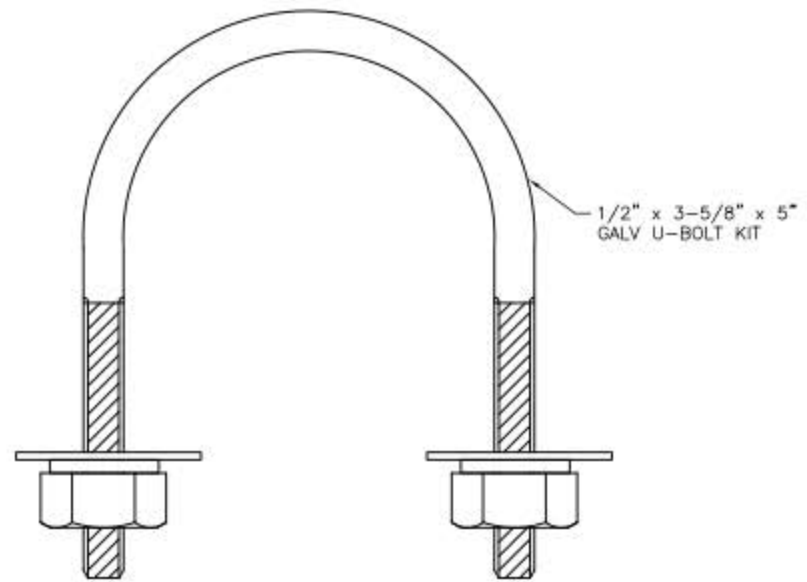
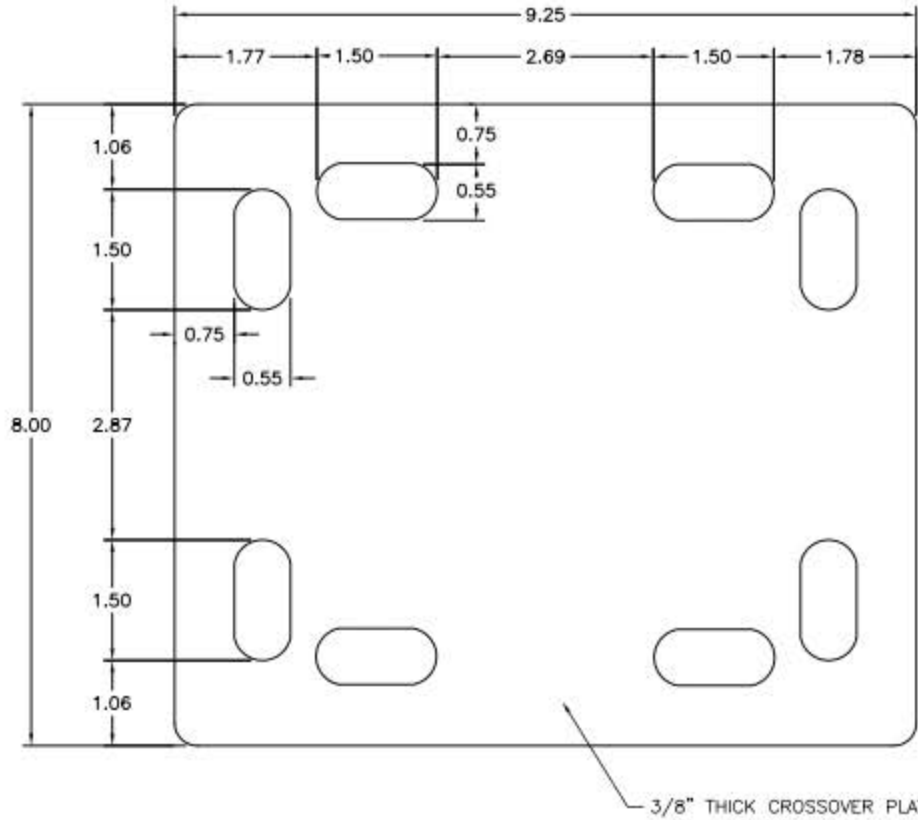

FINISH:
HOT DIP GALVANIZED

WEIGHT:
11.0LBS.

TOLERANCE UNITS

TOLERANCES ON DIMENSIONS, UNLESS OTHERWISE NOTED ARE:
 SAWED, SHEARED AND GAS CUT EDGES ($\pm .030$ ")
 DRILLED AND GAS CUT HOLES ($\pm .030$ ")—NO CONING OF HOLES
 LASER CUT EDGES AND HOLES ($\pm .010$ ")
 BENDS ARE $\pm 1/2$ DEGREE
 ALL OTHER MACHINING ($\pm .030$ ")
 ALL OTHER ASSEMBLY ($\pm .060$ ")

PROPRIETARY NOTE:

PART NO.		COP-3030	
DESCRIPTION			
CROSSOVER PLATE 3-1/2" O.D. TO 3-1/2" O.D.			
DRAWN BY:		REVISION:	
NMB		1	
CHECKED BY:		SCALE:	
DATE:		SHEET:	
09.21.17		1 OF 1	