

PARTS LIST			
ITEM	QTY	PART NO.	PART DESCRIPTION
1	1	SCX2	3/8" x 6" x 8" CROSSOVER PLATE
2	4	GUB-4352	1/2" x 3" x 5-1/4" GALV U-BOLT KIT

U-BOLT KIT INCLUDES:
 (1) GALVANIZED U-BOLT
 (2) GALVANIZED LOCK WASHERS
 (2) GALVANIZED FLAT WASHERS
 (2) GALVANIZED NUTS

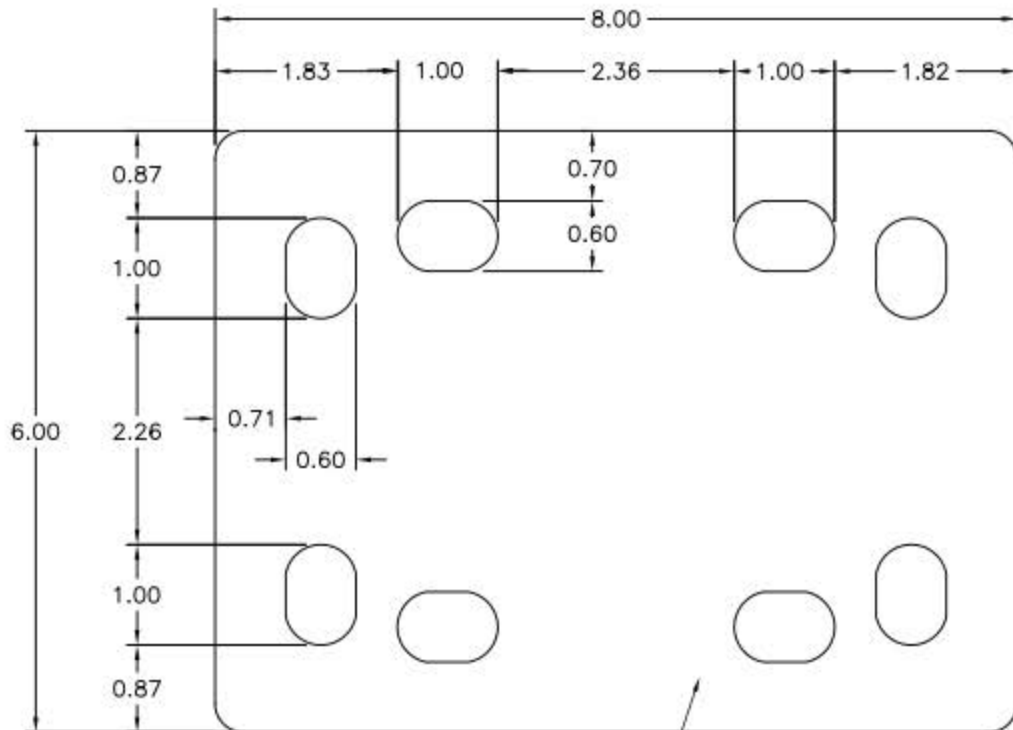

3/8" THICK CROSSOVER PLATE

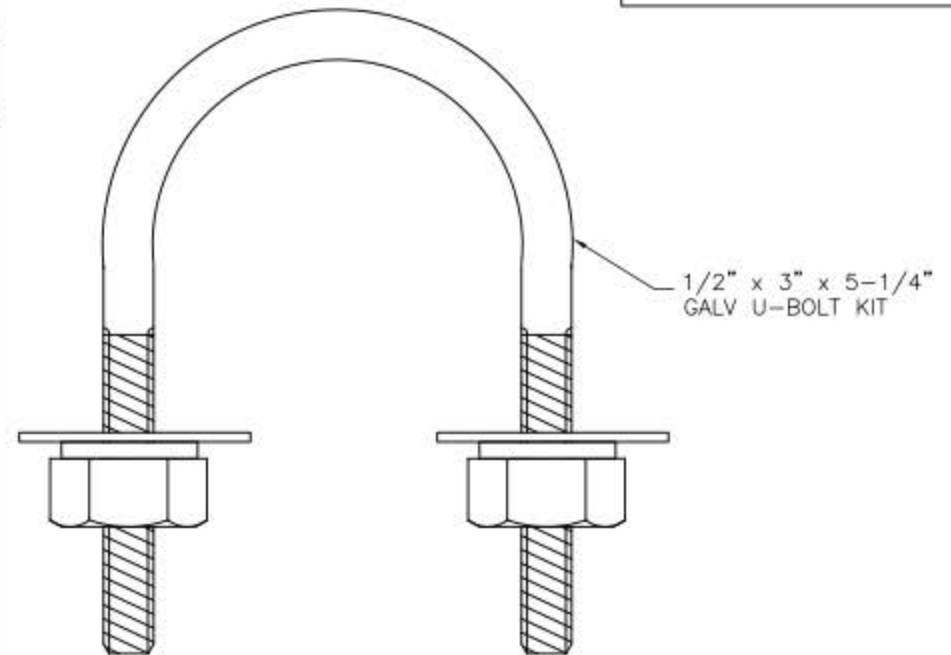

FINISH:
HOT DIP GALVANIZED

WEIGHT:
6.85LBS.

TOLERANCE UNITS

TOLERANCES ON DIMENSIONS, UNLESS OTHERWISE NOTED ARE:
 SAWED, SHEARED AND GAS CUT EDGES ($\pm .030"$)
 DRILLED AND GAS CUT HOLES ($\pm .030"$)—NO CONING OF HOLES
 LASER CUT EDGES AND HOLES ($\pm .010"$)
 BENDS ARE $\pm 1/2$ DEGREE
 ALL OTHER MACHINING ($\pm .030"$)
 ALL OTHER ASSEMBLY ($\pm .060"$)

PROPRIETARY NOTE:

PART NO.		COP-2525	
DESCRIPTION			
CROSSOVER PLATE 2-7/8" O.D. TO 2-7/8" O.D.			
DRAWN BY:		REVISION:	
CHECKED BY:		1	
DATE:		SCALE:	
09.21.17		-	
		SHEET:	
		1 OF 1	