

PARTS LIST			
ITEM	QTY	PART NO.	PART DESCRIPTION
1	1	SCX2	3/8" x 6" x 8" CROSSOVER PLATE
2	4	GUB-4240	1/2" x 2-1/2" x 4" GALV U-BOLT KIT

U-BOLT KIT INCLUDES:  
 (1) GALVANIZED U-BOLT  
 (2) GALVANIZED LOCK WASHERS  
 (2) GALVANIZED FLAT WASHERS  
 (2) GALVANIZED NUTS

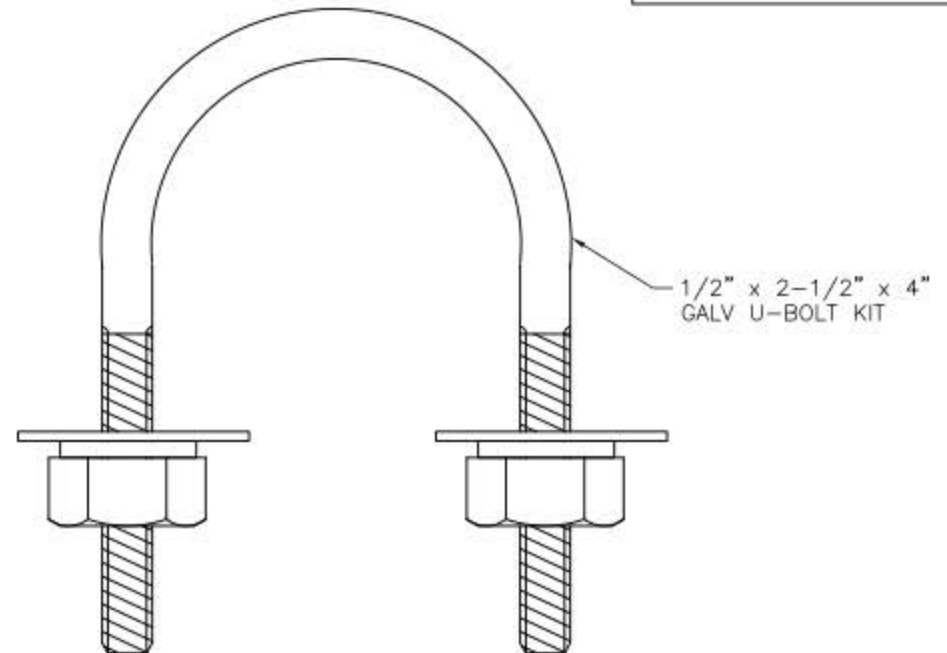
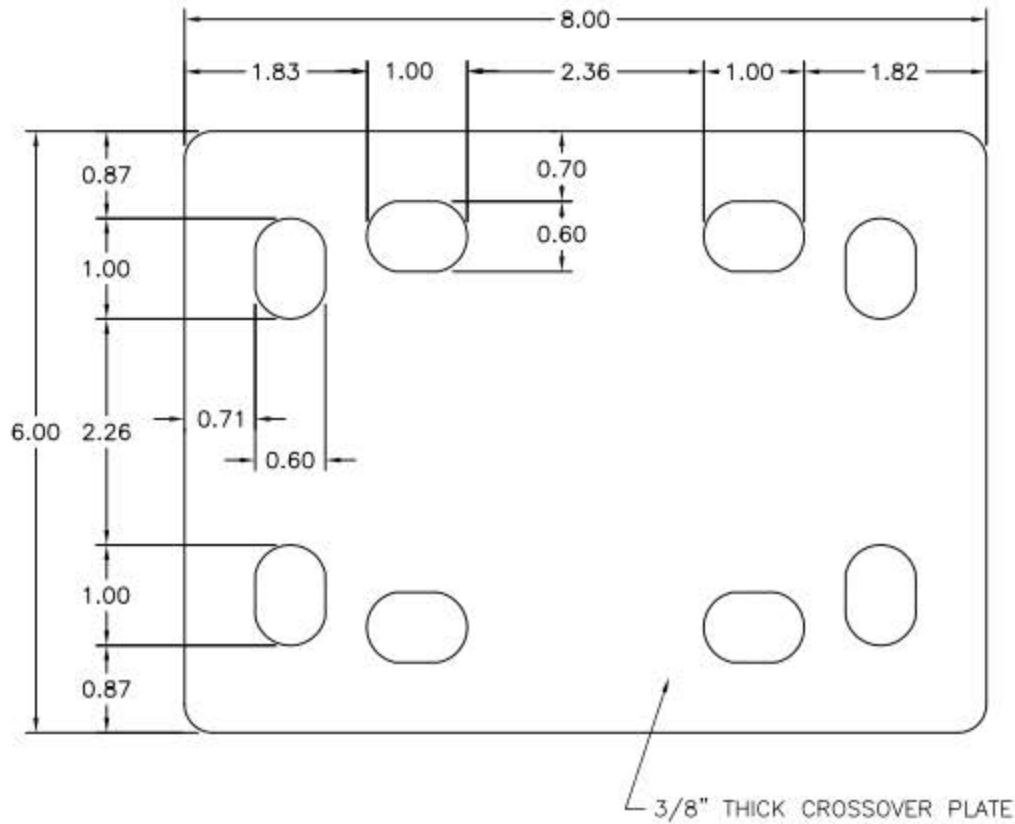

FINISH:  
HOT DIP GALVANIZED

WEIGHT:  
6.85LBS.

**TOLERANCE UNITS**

TOLERANCES ON DIMENSIONS, UNLESS OTHERWISE NOTED ARE:  
 SAWED, SHEARED AND GAS CUT EDGES ( $\pm .030$ "")  
 DRILLED AND GAS CUT HOLES ( $\pm .030$ "")—NO CONING OF HOLES  
 LASER CUT EDGES AND HOLES ( $\pm .010$ "")  
 BENDS ARE  $\pm 1/2$  DEGREE  
 ALL OTHER MACHINING ( $\pm .030$ "")  
 ALL OTHER ASSEMBLY ( $\pm .060$ "")

PROPRIETARY NOTE:

PART NO.		COP-2020	
DESCRIPTION			
CROSSOVER PLATE 2-3/8" O.D. TO 2-3/8" O.D.			
DRAWN BY:		REVISION:	
NMB		1	
CHECKED BY:		SCALE:	
DATE:		SHEET:	
09.21.17		1 OF 1	